

SINGULUS
MASTERING
THE ART OF MASTERING.



AM Direct

Recording directly to the stamper

*Now with 4X CD and
2R recording speed*

AM Direct

EASY, CLEAN AND AFFORDABLE IN-HOUSE MASTERING

Usually replicators postpone their investment in mastering until a certain minimum amount of stampers is consumed annually. Direct mastering now lowers this entry level significantly and brings mastering also to the small replicators, enabling them to fulfill customer orders in a shorter period of time and with much higher reliability.

The AM Direct is extremely easy to operate. The operator simply loads coated substrates for CD or DVD, chooses the appropriate process recipe via a user interface and then recording, development and sputter coating take place fully automatically. Only requiring final punching, a high signal quality stamper is available in record time.

The direct stamper recording process eliminates the electroforming step required for traditional glass mastering. Accordingly no hazardous chemical waste is created. This makes the AM Direct ideal for use in environmental sensitive areas.

Designed for today's business environment, the AM direct combines reliability and cost-effectiveness without any concession on quality. Proven technology such as a blue solid-state laser is employed to ensure the production of top-quality stampers.

From the original input media in less than one hour a stamper is made, ready to replicate.





MAIN FEATURES

- Low investment mastering for title from 1,500 up to 10,000 stampers / year (CD and DVD)
- Clean - no galvanics: cuts investment cost, eliminates hazardous chemicals
- Very easy operation
- High quality recording
- stamper performance identical to conventional glass mastering

substrate preparation not needed

exposure (LBR) recording at 405 nm

image reversal baking

integral exposure to UV-light, 380 nm

substrate immersed in developer solution

whole substrate exposed to deep UV 250 nm

hard-bake 5 min. at 220 °C

NiV sputtering
cleaning not necessary
protective coating
no back side sanding
punching

AM Direct Specification

Mastering Formats: Standardized Pre-recorded CD and DVD formats. All CD at 4x real time and DVD at 2 Reference recording speed

Media Input system:
- Supported Media: Gigabit networking environment

Optional:
- Copy Protection: CSS encryption
Several copy protection schemes available
- Networking: Mastering Super Highway networking connection, Cytris Direct downloading system, with one input drive of each (S)DLT tape / DVD-ROM input drive / CD-ROM input drive, networking storage with a variety of capacity

General details:
- Width: 1700 mm
- Length: 2600 mm
- Height: 1700 mm
- Weight: 1750 kg
- Room Conditions: Temperature 18 - 24 °C
Humidity 40 - 70 % RH

Laser Beam recorder:
- Type of Laser: Directly modulated Solid state laser diode (405 nm)
- Expected Life Time: > 9000 hours

Utility requirements:
- Electrical Supply: 230 / 400V 50 / 60 Hz
- Power Consumption: ~ 8kVA
- DI Water: < 3 l/h
- Argon Gas: ~ 4Nml / Master or 3.4Nml / min

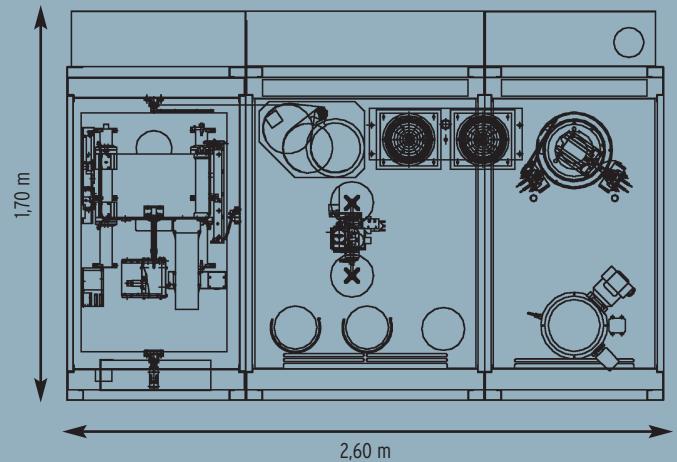

LATIN AMERICA
SINGULUS TECHNOLOGIES LATIN AMERICA Ltda.
Tel.: +55-11-36 43 01 13, Fax: +55-11-36 43 01 10
e-mail: latinamerica@singulus.com.br

SINGAPORE
SINGULUS TECHNOLOGIES Asia Pacific
Tel.: +65-67 41 19 12, Fax: +65-67 41 12 13
e-mail: singulus@singnet.com.sg

FRANCE
SINGULUS TECHNOLOGIES FRANCE S.A.R.L.
Tel.: +33-47-58 6 09 54, Fax: +33-47-58 6 09 55
e-mail: singulus@club-internet.fr

GREAT BRITAIN
SINGULUS TECHNOLOGIES UK Ltd.
Tel.: +44-1793-78 42 00, Fax: +44-17 93-78 42 22
e-mail: singulus_uk@msn.com

ITALY
SINGULUS TECHNOLOGIES ITALIA s.r.l.
Tel.: +39-71-7 93 03 12, Fax: +39-71-7 93 08 21
e-mail: singulus.italia@fastnet.it

SPAIN
SINGULUS TECHNOLOGIES Iberica
Tel.: +34-93-6 75 00 25, Fax: +34-93-5 90 64 26
e-mail: singulus@singulusib.com

HEADQUARTERS
Hanauer Landstrasse 103
D - 63796 Kahl, Germany
Tel.: +49 [0]61 88. 44 00
Fax: +49 [0]61 88. 44 01 10
e-mail: sales@singulus.de
Internet: www.singulus.de

TAIWAN
SINGULUS TECHNOLOGIES TAIWAN LTD.
Tel.: +886-2-87 51 20 15, Fax: +886-2-87 51 20 16
e-mail: sales@singulus.com.tw

UNITED STATES AND CANADA
SINGULUS TECHNOLOGIES Inc.
Tel.: +1-860-683 80 00, Fax: +1-860-683 80 10
e-mail: sales@singulus.com

US-WEST-COAST OFFICE
Tel.: +1-805-373 62 16, Fax: +1-805-371 74 33
e-mail: sales@singulus.com